



Issuing Entity:
Larson International Inc.
P.O. Box 638
Plainview, TX 79073-0638
U.S.A.
Phone 806-293-1353
Fax 806-293-5215
www.larsonintl.com

Bulletin No.: L17-001
Release Date: 01/30/17
Effective Date: Immediately
Supersedes: L16-006
Completion Date: 3/1/17*
Pages: 2

SERVICE BULLETIN

Ride Manufacturer: Larson International Inc. Affected Production Dates: 1998-2016
Ride Name: Giant Loop Affected Serial Nos.: 1,2,4-14

Abstract Of Issue:

The train undercarriage weldments may exhibit indications on or around the mounting cross tubes for the vehicle body attachment. Additional inspections and installation of gussets are outlined in this document.

Reason for Release:

Indications have been found on the undercarriage weldment mounting cross tubes and the adjacent area during routine inspections. This bulletin has a revised drawing with one additional gusset at each location. * If gussets have already been installed from the previous bulletin, this additional gusset can be installed during the next annual, no later than 3/1/18.

Action To Be Taken:

1. Update maintenance procedures to include the following ongoing inspections:
 - a. Monthly Inspection – visual inspection of undercarriage cross tubes and adjacent area (as shown below).
 - b. Annual Inspection (or 2,000 operating hours) – NDT MT of undercarriage cross tubes and adjacent area (as shown below).
2. Install gussets as shown on drawing “Undercarriage Repair 1-30-17”. NDT MT prior to gusset installation. Contact manufacturer for gussets and weld procedures.

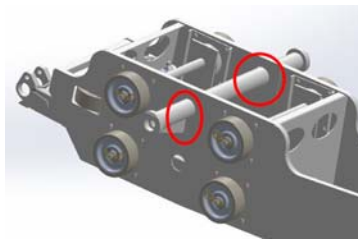

Larson International Inc. issues notifications for the benefit of owners of amusement rides manufactured by Larson International, Inc. As a service to the industry, and in the interest of employee and public safety, Larson International, Inc. also issues notifications for the benefit of owners of amusement ride equipment for which the manufacturer no longer exists such as LMC, Inc. and Hi-Roller Company. In doing so, Larson International, Inc. does not assume liability for losses associated with amusement ride equipment built by manufacturers other than Larson International, Inc.



Issuing Entity:
 Larson International Inc.
 P.O. Box 638
 Plainview, TX 79073-0638
 U.S.A.
 Phone 806-293-1353
 Fax 806-293-5215
 www.larsonintl.com

Bulletin No.: L17-001
 Release Date: 01/30/17
 Effective Date: Immediately
 Supersedes: L16-006
 Completion Date: 3/1/17*
 Pages: 2

REV	E.C.O.	REVISION DESCRIPTION	DATE	BY

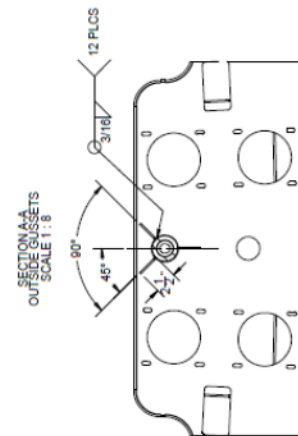
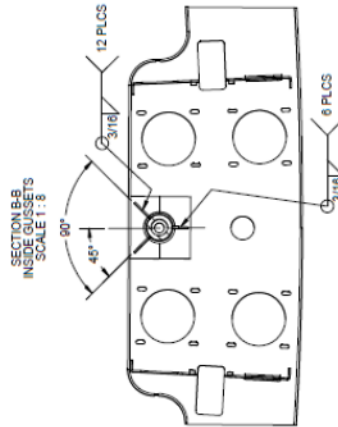
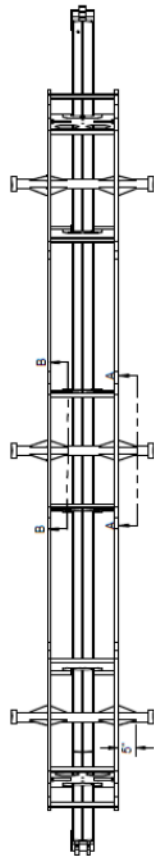
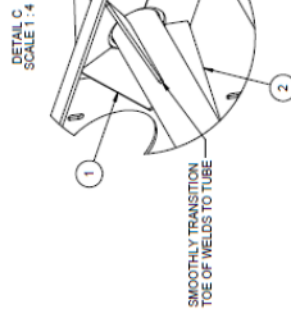
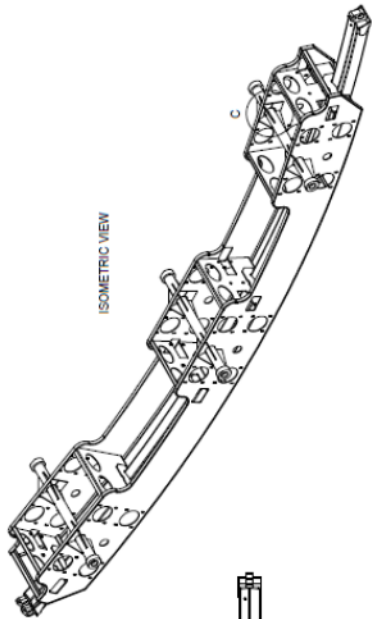

NOTES:
 1) WRAP WELD AROUND ENDS OF GUSSET
 TO BLEND THE GUSSET WELD TO THE TUBE
 TO MAKE A SMOOTH TRANSITION
 (SEE DETAIL C)
 2) NOT (MT) ALL WELDS AFTER COOLED.
 NO INDICATIONS PERMITTED.
 * MATERIAL NOTE:
 ASTM A38 IS ALSO ACCEPTABLE MATERIAL

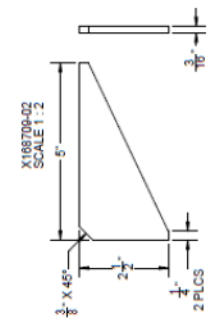
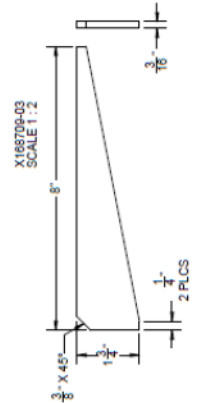

ITEM NO.	PART NUMBER	DESCRIPTION	MATERIAL	QTY
2	X188709-03	PL. 3/16" X 2 1/2" X 8"	ASTM A57/21 6	8
1	X188709-02	PL. 3/16" X 2 1/2" X 5"	ASTM A57/21 24	24
DESCRIPTION			GIANT LOOP	
MATERIAL			UNDERCARRIAGE REPAIR	
NO. NUMBER			1-30-17	
SCALE			1:50	
REVISION			15879-00	
QUANTITY			2	REORDER
WEIGHT			902.57 lb	
DRAWING NUMBER				