



**CHANCE RIDES MANUFACTURING, INC.**  
**4200 Walker**  
**Wichita, KS 67277-2328**  
**U.S.A.**  
**Phone: 1-316-942-7411 • FAX: 1-316-942-7416**  
**Website: www.chancerides.com**  
**E-mail: rides@chancerides.com**

Bulletin No:	B106CRM192-0
ReleaseDate:	November21,2014
EffectiveDate:	November21,2014
Supersedes:	N / A
Completion Date:	See Text
Page:	1 of 2

# SERVICE BULLETIN

Ride Manufacturer: CHANCE RIDES, INC.      Affected Production Dates: All

Ride Name: ZIPPER      Affected Serial Nos.: All

Model No.: 106

Abstract of Issue:  
 Seat Support Frame Inspection

**Reason For Release:**  
 After many years of operation, the structural integrity of the seat support frames on the ZIPPER amusement ride can become compromised due to corrosion. Like most steel ride components, this condition is more likely to occur when operated in coastal or other wet locations. If a seat support frame is weakened sufficiently, it can fail, resulting in personal injury to passengers, operators or bystanders.

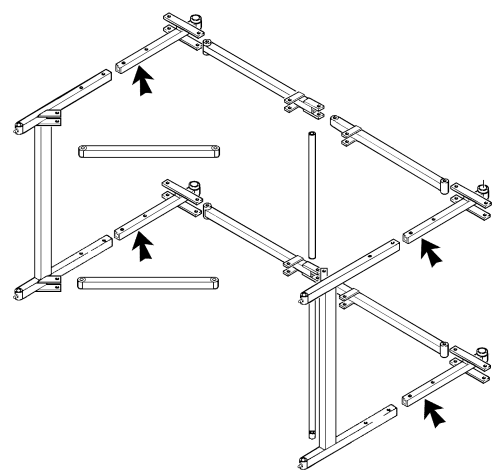

All steel components must be visually monitored on an on-going basis, as part of a comprehensive maintenance and inspection program. Some susceptible areas, however, are not visible without partial disassembly of the components.

This bulletin describes additional procedures required to inspect the seat support frames in the indicated areas.

**Action to be Taken:**  
 All owner/operators of the above noted amusement rides must inspect seat support frames for damage and/or deterioration as described in this bulletin. This inspection must be performed initially within 30 days of the receipt of this bulletin. Thereafter, the seat support frames must be inspected annually using the same procedure.

Observe all safety information contained in the manufacturer’s manuals. Make available this bulletin and all related technical information to personnel using the equipment.

Chance Rides Manufacturing, Inc. issues notifications for the benefit of owners of amusement rides manufactured by Chance Rides Manufacturing, Inc. As a service to the industry, and in the interest of employee and public safety, Chance Rides Manufacturing, Inc. also issues notifications for the benefit of owners of amusement ride equipment for which the manufacturer no longer exists, such as the Allan Herschell Company, Chance Manufacturing Co., Inc., Chance Rides, Inc., etc. In doing so, Chance Rides Manufacturing, Inc. does not assume liability for losses associated with amusement ride equipment built by manufacturers other than Chance Rides Manufacturing, Inc.



**CHANCE RIDES MANUFACTURING, INC.**

**4200 Walker**

**Wichita, KS 67277-2328**

**U.S.A.**

**Phone: 1-316-942-7411 • FAX: 1-316-942-7416**

**Website: [www.chancerides.com](http://www.chancerides.com)**

**E-mail: [rides@chancerides.com](mailto:rides@chancerides.com)**

Bulletin No: B106CRM192-0

ReleaseDate: November21,2014

EffectiveDate: November21,2014

Supersedes: N / A

Completion Date: See Text

Page: 2 of 2

Ride Manufacturer: CHANCE RIDES, INC. Affected Production Dates: All

Ride Name: ZIPPER Affected Serial Nos.: All

Model No.: 106

Detail of Issue

### **Inspection Procedure**

Carefully inspect the sliding joints on all seat support frames. These joints must be disassembled for inspection.

- After disassembly, clean the area around the holes to remove rust, grease, etc.
- Visually inspect the area. Look for excessive corrosion on the tube surface and around the holes.
- Inspect for cracks around the holes. A visible line around the reinforcing tube is normal, but no cracks are allowed.
- If uncertain as to whether a crack is present, magnetic particle inspection can be performed using dry powder and an AC or DC yoke.
- If any indication is found, refer to the "Repair Procedure" below.
- Before re-assembling, apply a corrosion-resistant coating to the sliding surfaces.

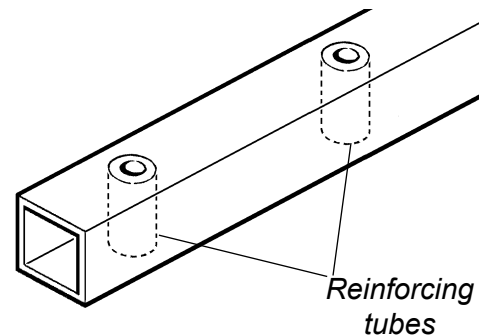

### **Repair Procedure**

**If the crack is concentric to the hole**, and is less than one third of the circumference, it can be repaired as follows:

- Grind out the crack using a sharp pointed rotary file. Do not remove any more material than necessary.
- Use appropriate NDT method to confirm that all of the indication has been completely removed.
- Pre-heat the reinforcing tube to 100°F.
- Using ER70S6 (gas metal arc welding), fill the gap making sure to get good penetration into the reinforcing tube without burning away the wall of the square tube.

***NOTE: All welding must be performed by a person certified in accordance with American Welding Society (AWS) D1.1 for the process and position required for the specific work being done.***

- Sand the weld bead just enough to allow smooth movement of the inner and outer tubes of the sliding joint. Do not remove any more material than necessary.

**If the crack extends out into the square tube**, Contact the Chance Customer Service Department to determine if repair is recommended.